

**NOTES UNLESS OTHERWISE SPECIFIED**

1. MATERIAL: 13 GA (.093") PARENT 304 STAINLESS STEEL
2. WELD REQUIREMENTS: MINIMIZE WELD POROSITY AND BE VISUALLY FREE OF CRACKS. WELDS TO BE SMOOTH AFTER WELDING.
3. INSIDE FINISH: 32 Ra.
4. OUTSIDE FINISH: 60-80 Ra. OVERALL. PARTS WITH SCRATCHES OR IMPERFECTIONS SMALLER THAN 1/2" ARE PASSED ON QUALITY INSPECTION.
5. REMOVE ALL SHARP EDGES AND BURRS. BREAK WITH A .02 IN X 45 DEG CHAMFER OR .02 IN RADII.
6. DESIGN IS PER CUSTOMER SPECIFICATIONS. TMS IS PROVIDING DRAWING SUPPORT ONLY AND UNDER NO CIRCUMSTANCE MAKES ANY CLAIMS FOR PERFORMANCE. TMS ASSUMES NO LIABILITY FOR THE DESIGN REGARDLESS OF ITS USE AND OR METHOD OF INSTALLATION.

REVISIONS				
ZONE	REV.	DESCRIPTION	DATE	APPROVED
	A	INITIAL RELEASE FOR MANUFACTURING	22OCT2020	K.SCRIVENER
	B	FORMAT CHANGES	5NOV2020	A.FULKERT
	C	CHANGED OVERALL HEIGHT	5NOV2020	A.FULKERT
	D	.45 MIN WALL THICKNESS	9DEC2020	A.FULKERT

D  
C  
B  
A

D  
C  
B  
A

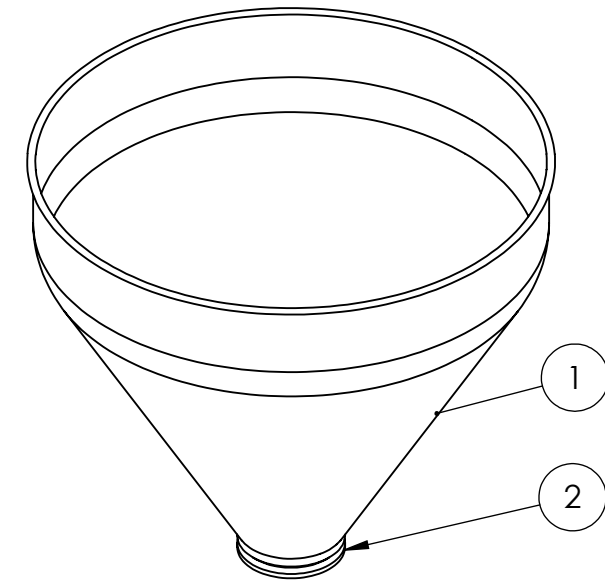

ISOMETRIC VIEW  
SCALE 1:8

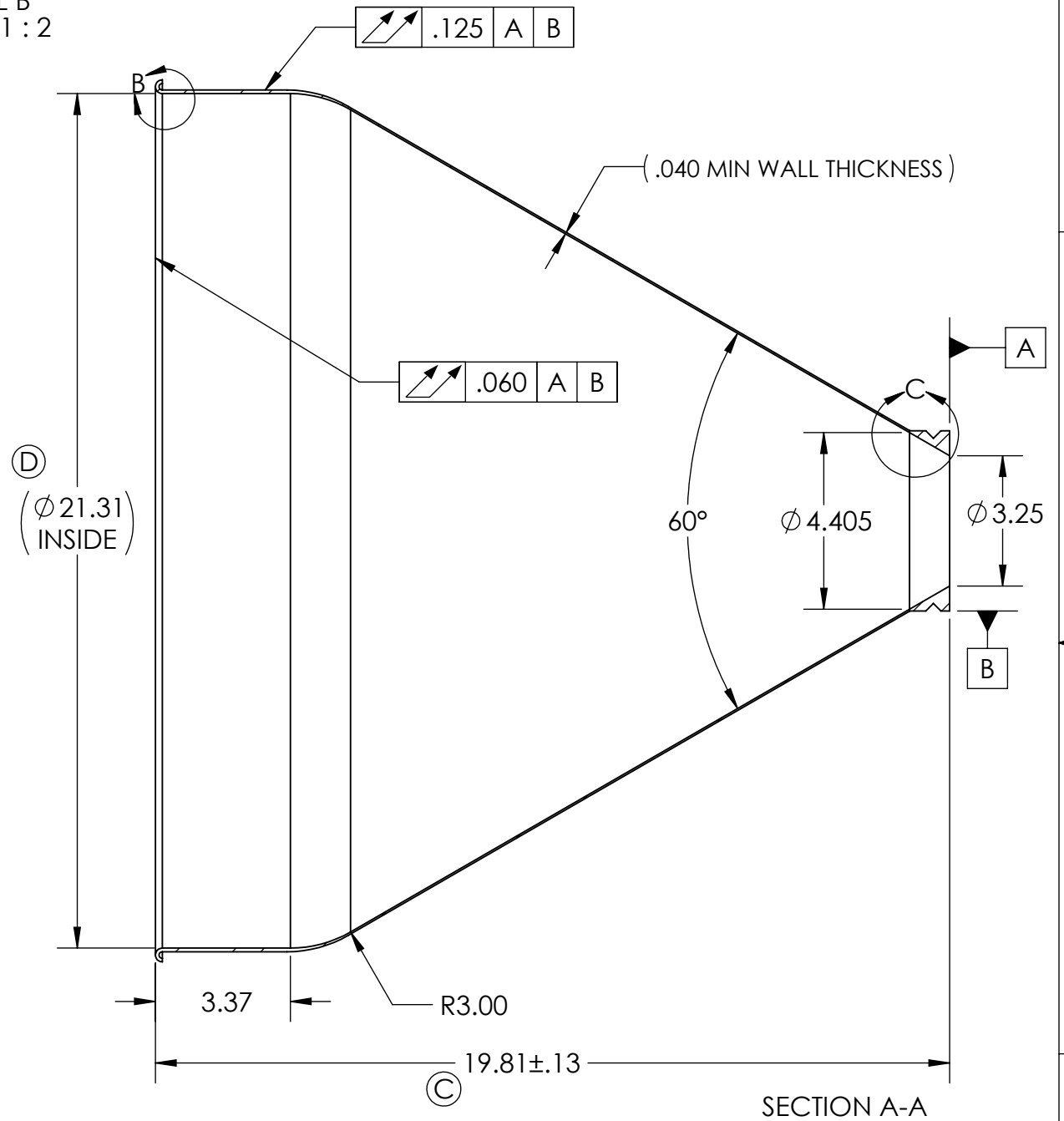
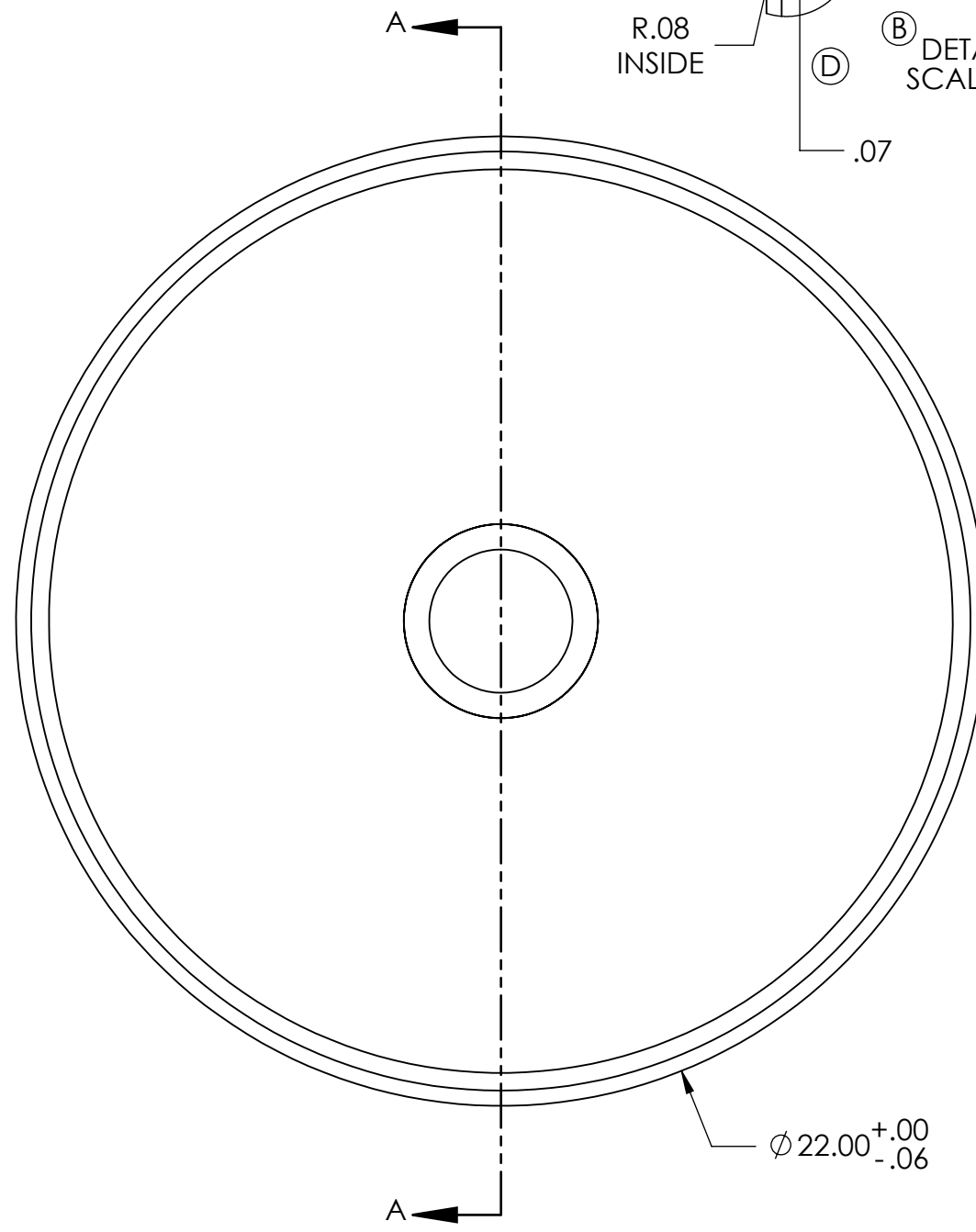

SECTION A-A

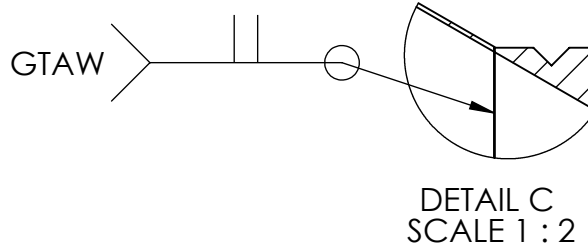

DETAIL C  
SCALE 1:2

ITEM NO.	PART NUMBER	DESCRIPTION	QTY.
1	S121028-1	304SS HOPPER	1
2	TMS-COLLAR-3.25	304SS FERRULE	1

**PROPRIETARY AND CONFIDENTIAL**  
THE INFORMATION CONTAINED IN THIS DRAWING IS THE SOLE PROPERTY OF TOLEDO METAL SPINNING COMPANY. ANY REPRODUCTION IN PART OR AS A WHOLE WITHOUT THE WRITTEN PERMISSION OF TOLEDO METAL SPINNING COMPANY IS PROHIBITED.

UNLESS OTHERWISE SPECIFIED:			
1. DIMENSIONS ARE IN INCHES	DRAWN	NAME	DATE
2. TOLERANCE: FRACTIONAL ± .25 X.X ± .1 X.XX ± .03 X.XXX ± .01 ANGULAR: ± 2 DEG.	CHECKED		
3. THIRD ANGLE PROJECTION	ENG APPR.		
INTERPRET DRAWING PER ASME-Y14.5M-1994 STANDARDS MATERIAL	MFG APPR.		
FINISH	Q.A.		
DO NOT SCALE DRAWING	COMMENTS:		

TOLEDO METAL SPINNING Co.		
TITLE: HOPPER-22" STRAIGHT SIDE WITH 3-1/4" OPENING		
SIZE B	DWG. NO. TMS22-3.25	REV D
SCALE: 1:4	WEIGHT:	SHEET 1 OF 1

8 7 6 5 4 3 2 1