

NOTES UNLESS OTHERWISE SPECIFIED

- 1. PARENT MATERIAL: 304 STAINLESS STEEL, 18 GAUGE (0.048" THICK)
- 2. PART IS SEAMLESS, FORMED FROM SHEET METAL WITHOUT WELDS.
- 3. FINISH: NO METAL FINISHING REQUIRED. THE FINAL FINISH SHALL BE THE RESULT OF THE PROCESSES USED TO FABRICATE THE SHAPE, RESULTING IN AN ESTIMATED SURFACE ROUGHNESS OF 80 Ra.

REVISIONS			
REV.	DESCRIPTION	DATE	APPROVED
00	INITIAL RELEASE FOR MANUFACTURING	21JAN2010	L.FERNANDO
A	Updated sheet format, changed ID from 25.50" to 25.32", changed Bead shape, changed OAH from 5.10" to 5.20", changed Step Height from 0.45" to 0.80".	15JAN2015	A.FULKERT
B	Updated sheet format, corrected title block and revision block author information, changed Radius from 0.125" to 0.15", changed Step Height from 0.80" to 0.50", changed OAH from 5.20" to 4.90", changed Dome Radius from 27.00" to 27.00" ref.	MAR2019	R.DAVIS

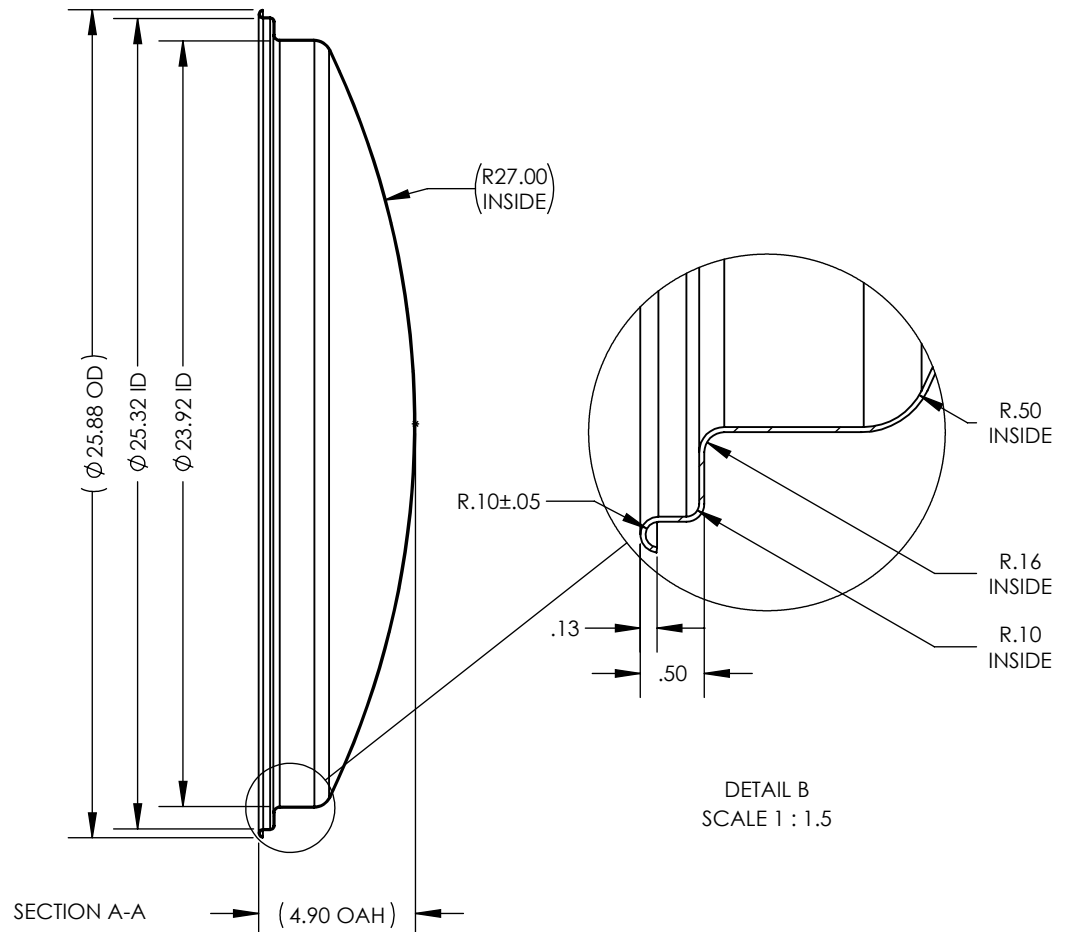
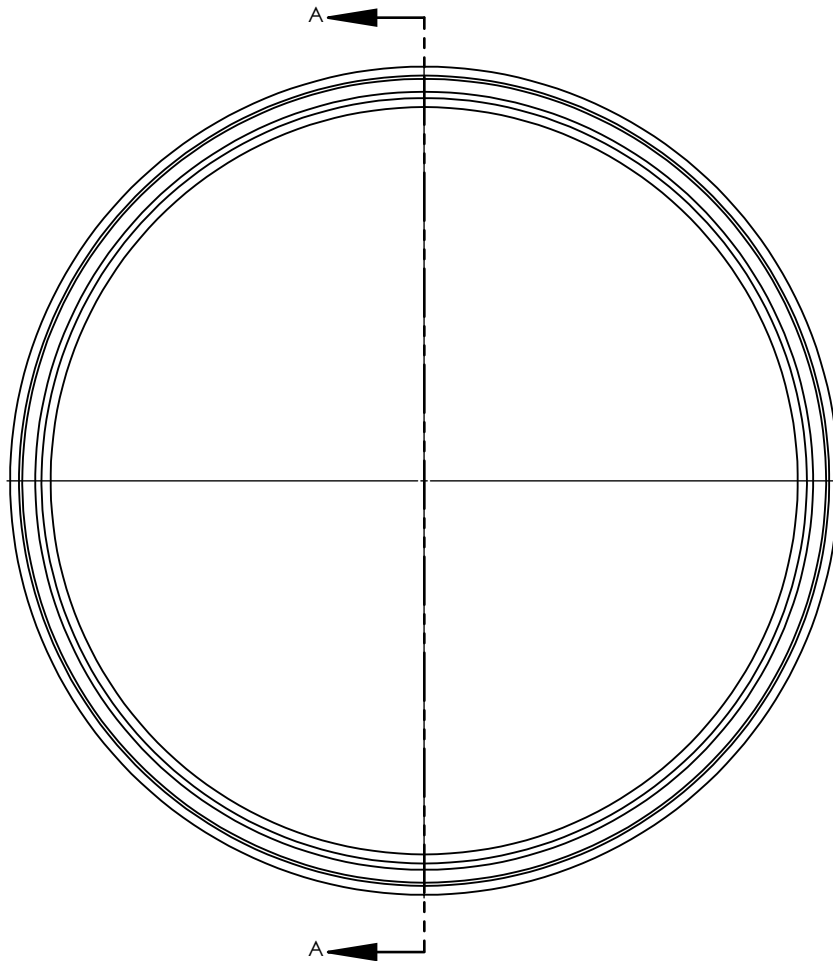

SCALE 1 : 12

UNLESS OTHERWISE SPECIFIED:
 1. DO NOT SCALE DRAWING
 2. DIMENSIONS ARE IN INCHES
 3. TOLERANCE:
 FRACTIONAL ± .25
 X.X ±.1
 X.XX ±.03
 X.XXX ±.010
 ANGULAR: ±2 DEG.
 4. INTERPRET DRAWING PER ASME-Y14.5M-1994 STANDARDS
 5. THIRD ANGLE PROJECTION
 6. REMOVE BURRS & BREAK ALL SHARP EDGES WITH R0.03 ±.02

	NAME	DATE
DRAWN	R.DAVIS	MAR2019
CHECKED		
ENG APPR.		
MFG APPR.		
Q.A.		

PROPRIETARY AND CONFIDENTIAL
 THE INFORMATION CONTAINED WITHIN THIS DRAWING IS THE SOLE PROPERTY OF TOLEDO METAL SPINNING COMPANY. ANY REPRODUCTION IN PART OR AS A WHOLE WITHOUT WRITTEN PERMISSION OF TOLEDO METAL SPINNING COMPANY IS PROHIBITED.

TOLEDO METAL SPINNING COMPANY
 EST. 1929

TITLE:
 TMS 304SS BEADED DOME LID

SIZE	DRAWING NUMBER	REV
A	TMSLD2418-BEADED REV B	B
SCALE: 1:6		WEIGHT: 8.61
SHEET 1 OF 1		