

**NOTES UNLESS OTHERWISE SPECIFIED**

- 1. MATERIAL: .125" (11 GA.) 304 STAINLESS STEEL
- 2. FINISH: NO METAL FINISHING REQUIRED. THE FINAL FINISH SHALL BE THE RESULT OF THE PROCESSES USED TO FABRICATE THE SHAPE.

REVISIONS			
REV.	DESCRIPTION	DATE	APPROVED
A	INITIAL RELEASE FOR MANUFACTURING	19SEP2017	B.KEEL
B	UPDATED DRAWING TO CURRENT FORMAT	16JUL2020	K.DRUMHILLER
C	ADDED MATERIAL THICKNESS DIMENSIONS	12/13/2021	M.BODETTE

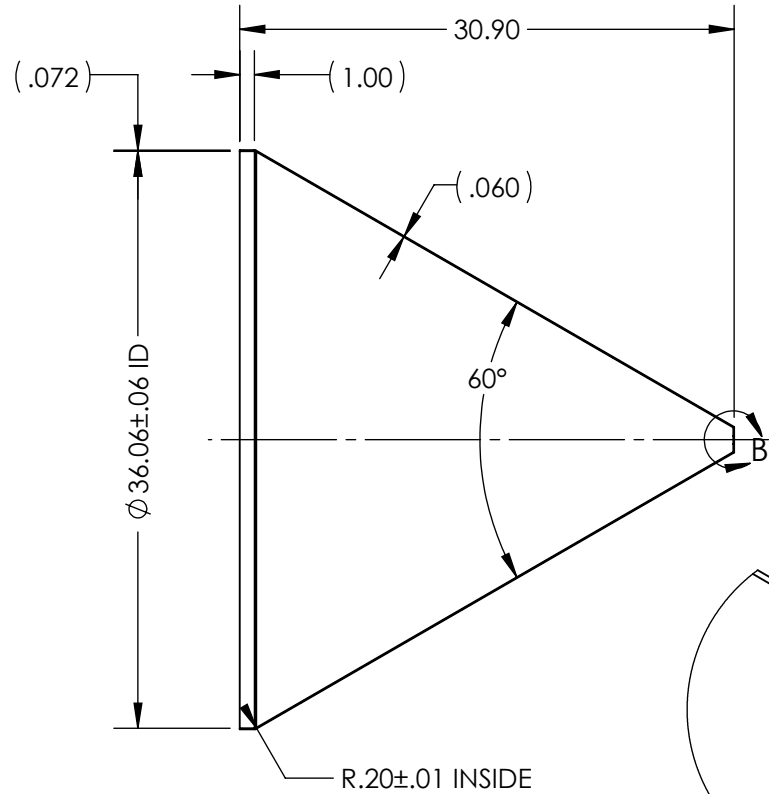
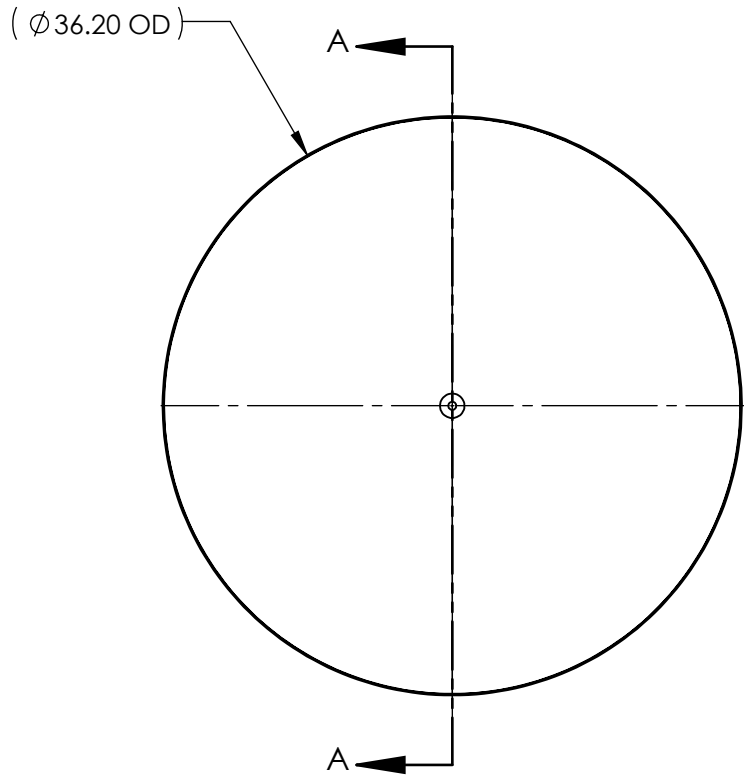

SECTION A-A

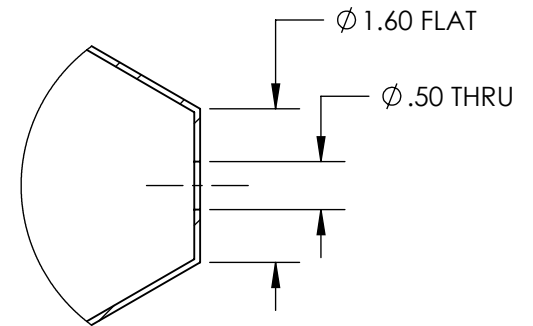

DETAIL B  
SCALE 1 : 2

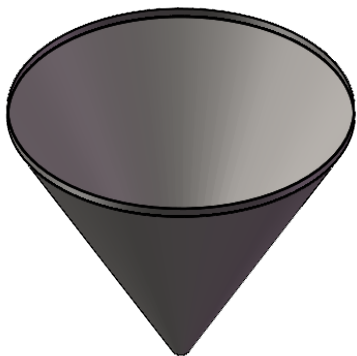

- UNLESS OTHERWISE SPECIFIED:
1. DO NOT SCALE DRAWING
  2. DIMENSIONS ARE IN INCHES
  3. TOLERANCE:  
 FRACTIONAL ± .25  
 X.X ± .1  
 X.XX ± .03  
 X.XXX ± .010  
 ANGULAR: ± 2 DEG.
  4. INTERPRET DRAWING PER ASME-Y14.5M-1994 STANDARDS
  5. THIRD ANGLE PROJECTION
  6. REMOVE BURRS & BREAK ALL SHARP EDGES WITH R0.03 ± .02

	NAME	DATE
DRAWN	K.SCRIVENER	19SEP2017
<b>PROPRIETARY AND CONFIDENTIAL</b>		
THE INFORMATION CONTAINED WITHIN THIS DRAWING IS THE SOLE PROPERTY OF TOLEDO METAL SPINNING COMPANY. ANY REPRODUCTION IN PART OR AS A WHOLE WITHOUT WRITTEN PERMISSION OF TOLEDO METAL SPINNING COMPANY IS PROHIBITED.		

**TOLEDO METAL SPINNING EST. 1929**

TITLE:  
**36" HOPPER WITH 1" STRAIGHT WALL**

SIZE <b>A</b>	DRAWING NUMBER <b>TMS36111</b>	REV <b>C</b>
------------------	-----------------------------------	-----------------